

# PainStation

## User Manual for Model 2.5

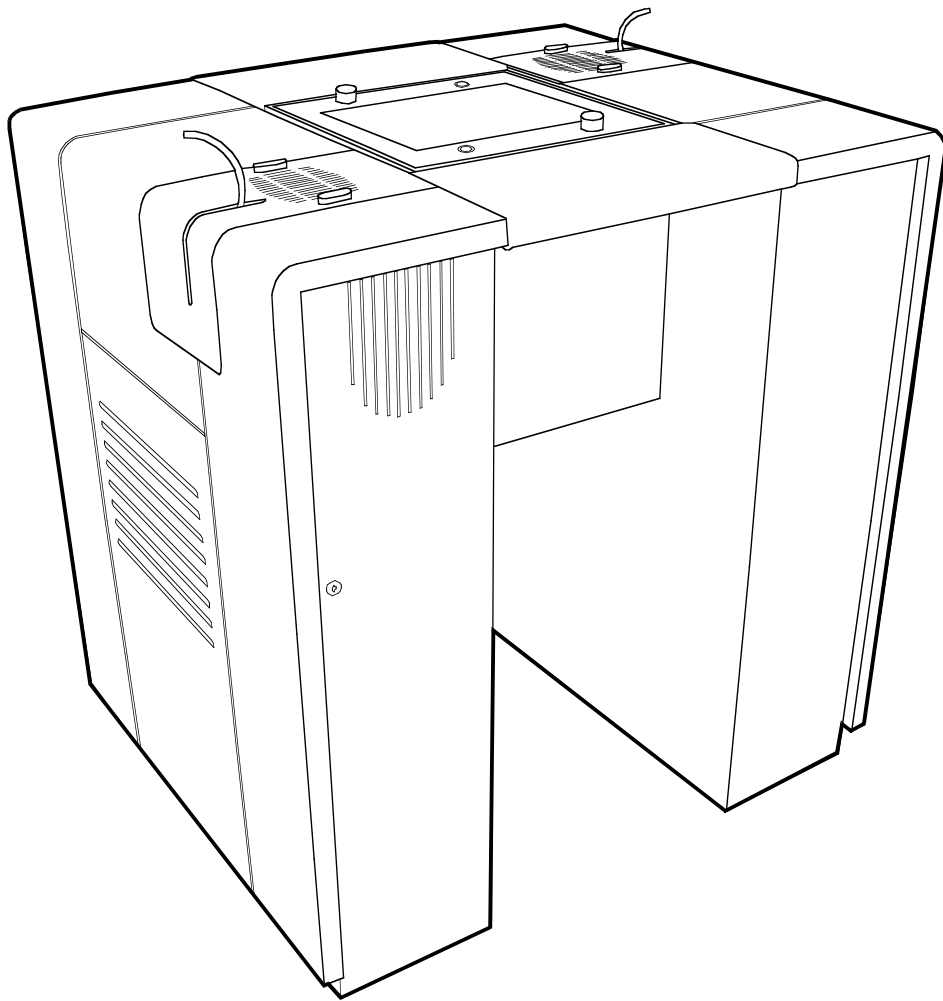

# Contents

<b>A. Handling Instructions</b>	
Moving and Lifting	3
<b>B. Everyday Usage</b>	
Overview	5
Connecting power supply	6
Main Power Switch	6
Turning the machine on/off	7
Adjusting Volume	7
Exchanging Whips	8
Cleaning	9
<b>C. Troubleshooting</b>	
PainControlUnit	10
Resetting electronics	10
<b>D. Credits</b>	
People	11

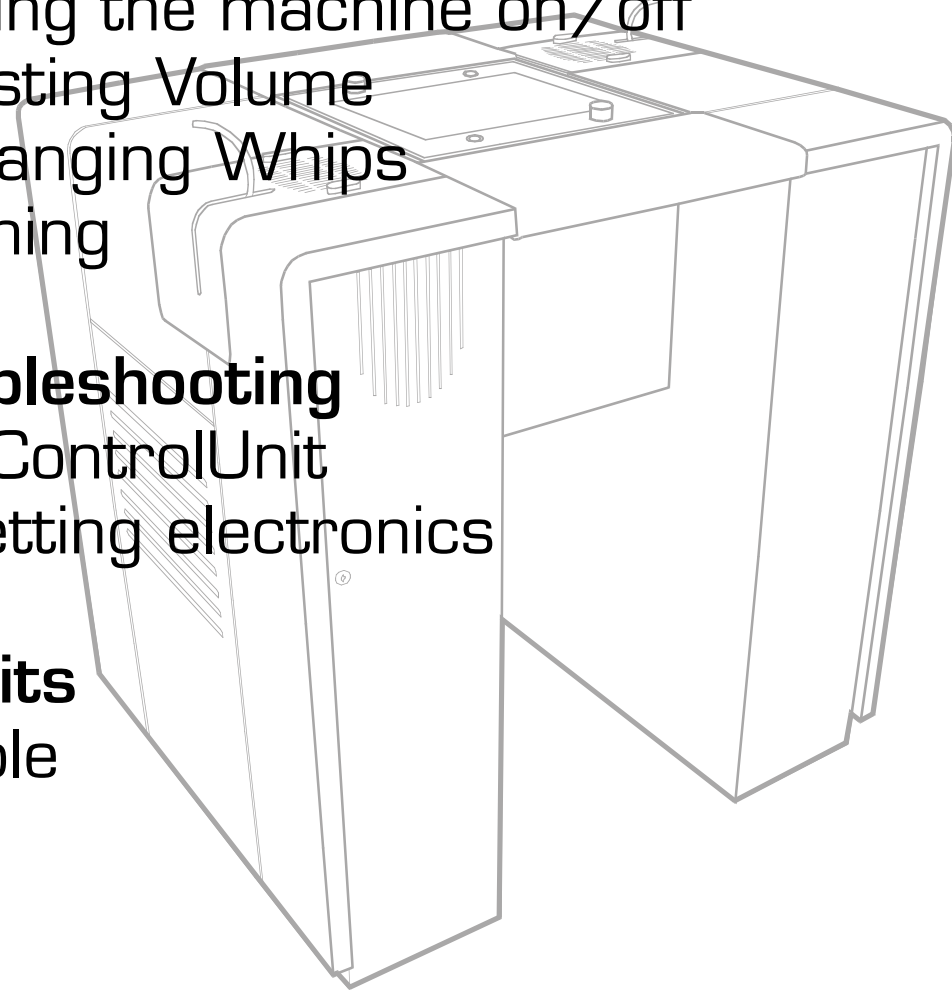

# WRONG!!



**DO NOT CARRY HERE!!**  
**THE ARM RESTS ARE NOT BUILT TO**  
**SUPPORT THE WEIGHT OF THE MACHINE!**  
**2 PEOPLE ARE NOT ENOUGH**  
**TO MOVE THE MACHINE!**

# CORRECT!!

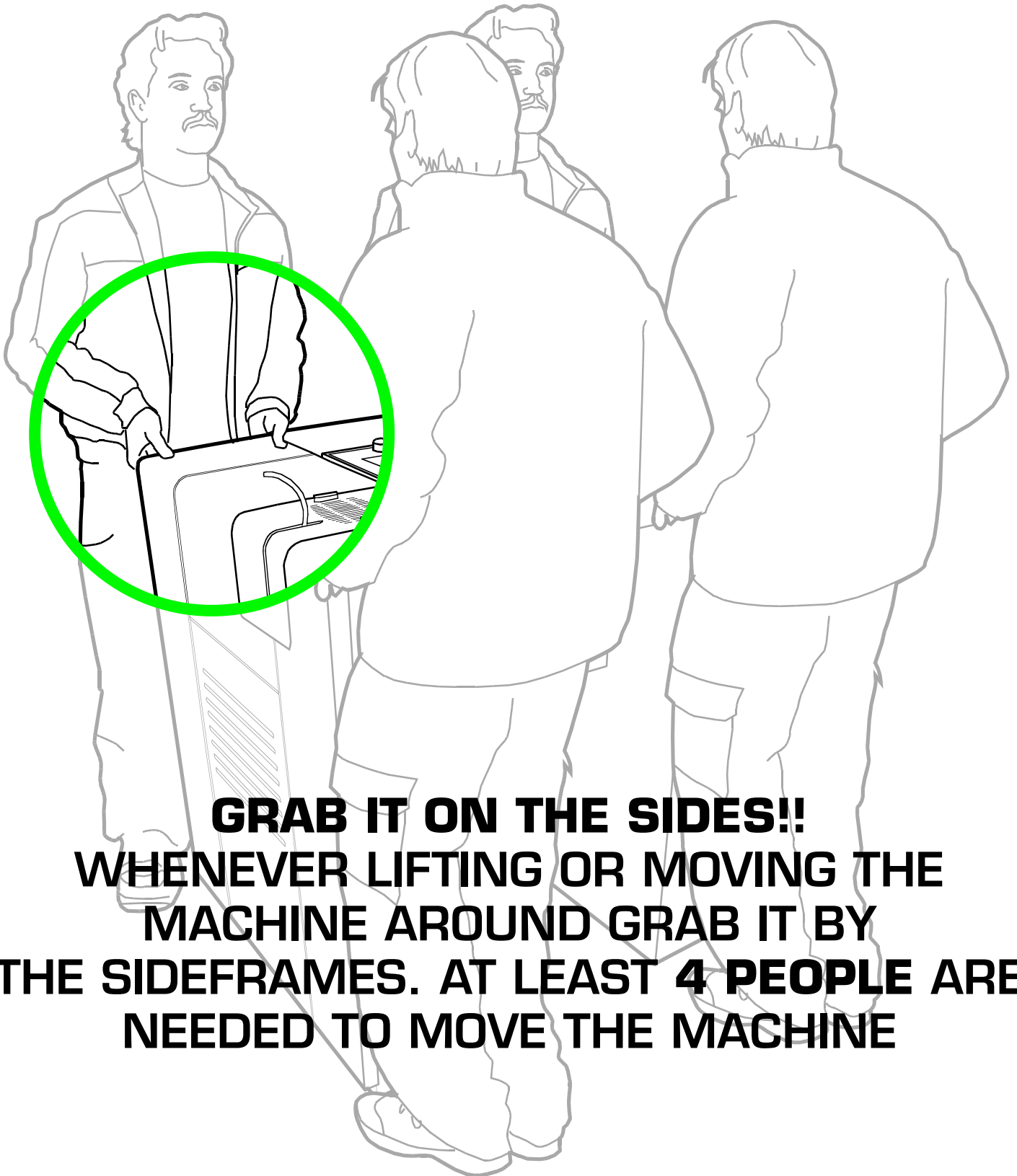

**GRAB IT ON THE SIDES!!  
WHENEVER LIFTING OR MOVING THE  
MACHINE AROUND GRAB IT BY  
THE SIDEFAMES. AT LEAST 4 PEOPLE ARE  
NEEDED TO MOVE THE MACHINE**

# Overview

## **PainExecutionUnit (PEU)**

Exchange Whips, Clean and Disinfect.

See page 8

## **PC Side (Player 1)**

Power On/Off,  
Adjust Volume.  
See page 7

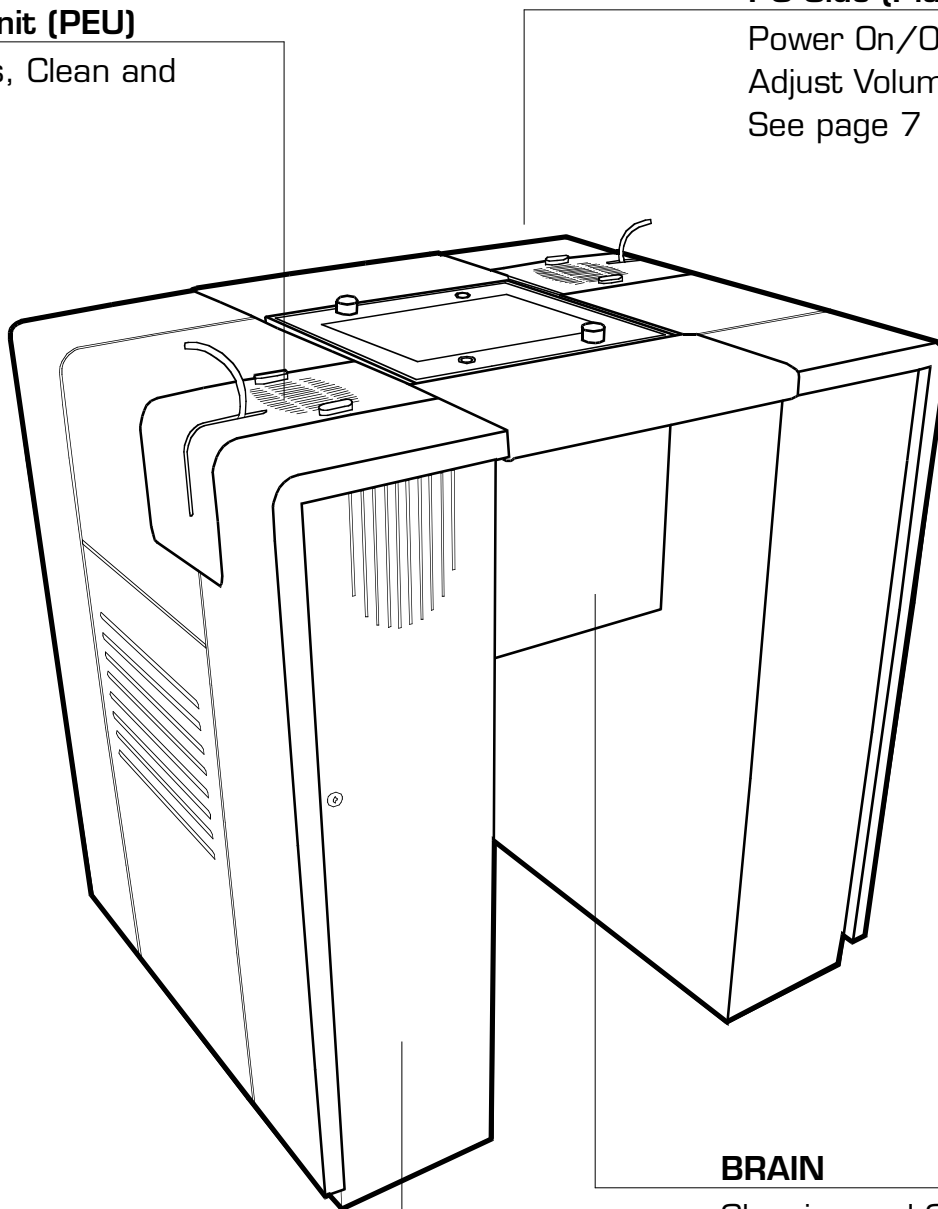

## **BRAIN**

Cleaning and Caressing  
See page 9

## **Electronics Side (Player 2)**

Power cord, Main Power switch

See page 6

PainControlUnit

see page 10

# Power Cord

## Main Power Switch

### Electronics Side (Player 2)

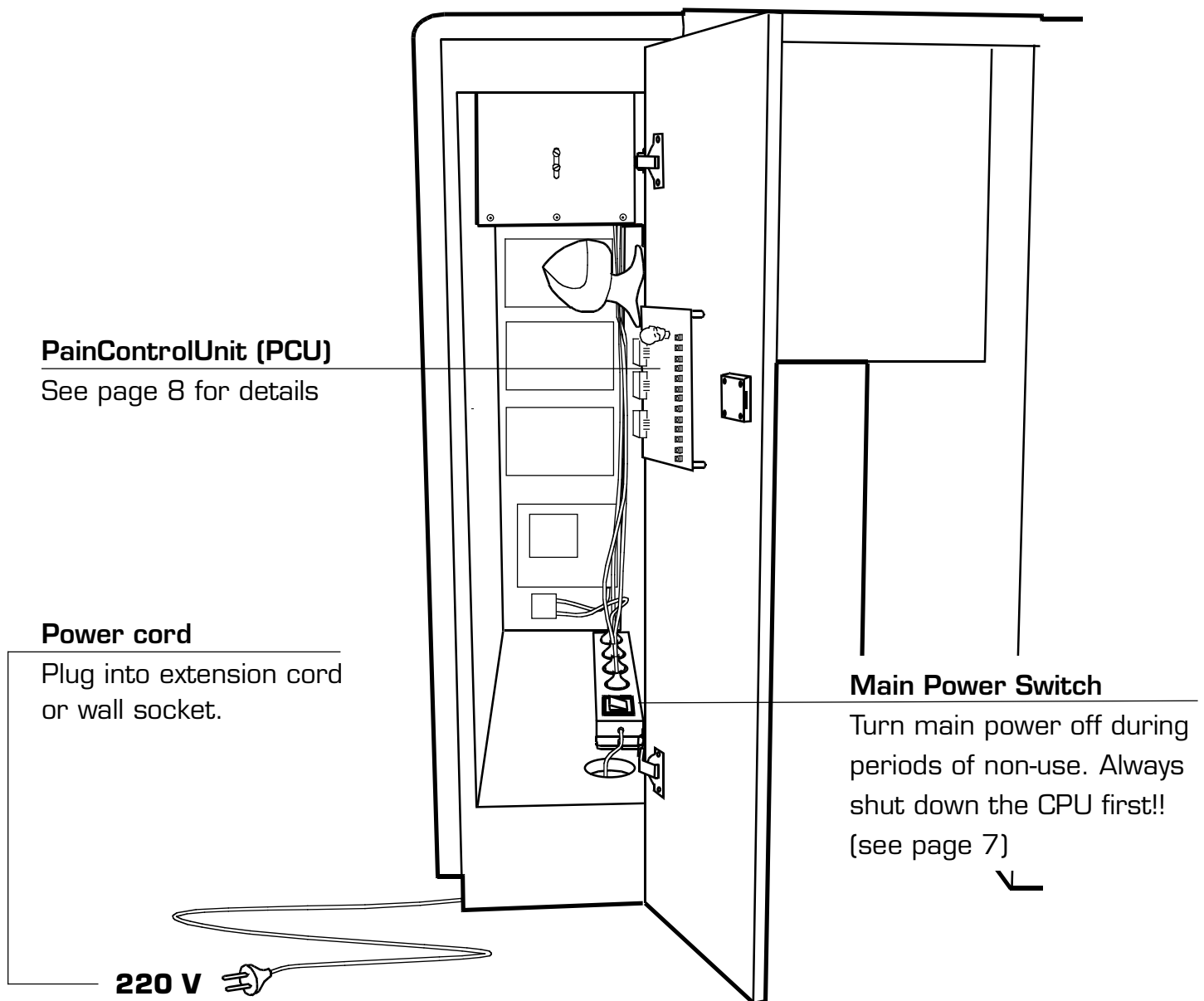

Keep sideframes locked at all times to prevent misuse and possible accidents!

# Power on/off

## Adjusting volume

### CPU Side (Player 1)

#### Adjust Volume

Rotate Speaker towards you.  
Use knob in middle to adjust volume.



#### Power On/Off

Always use red button on the back of PC to start up and shut down the machine.

Keep sideframes locked at all times to prevent misuse and possible accidents!

# Exchanging whips

## PainExecutionUnit (PEU)

### Disinfect surface

Clean the PEU surface regularly. Use alcohol or other to disinfectant, especially after open wounds have occurred!

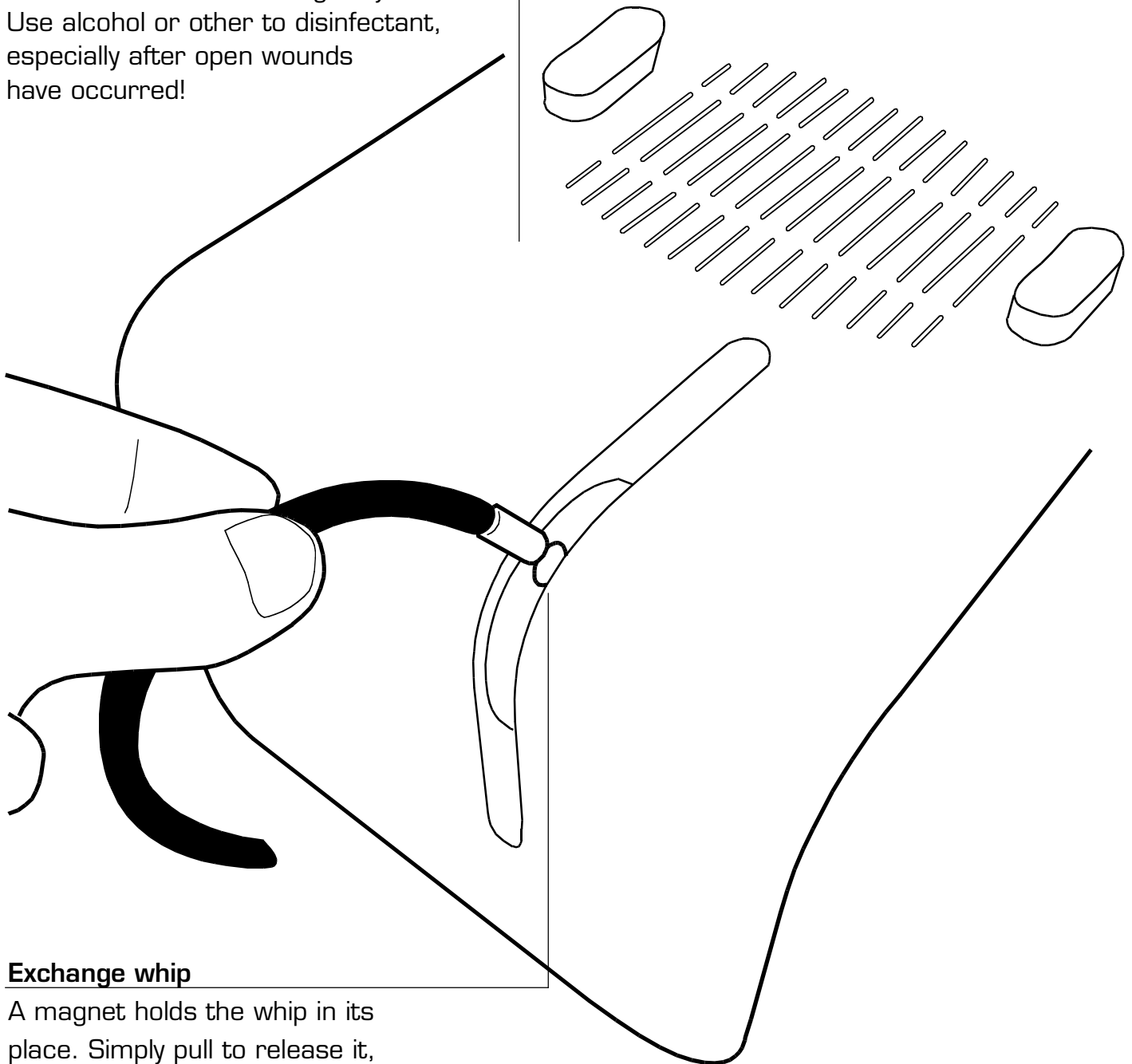

### Exchange whip

A magnet holds the whip in its place. Simply pull to release it, plug back in to attach.

# PainControlUnit (PCU) Electronics Side (Player 2)

The PCU can be used to test the functionality of the pain executing devices (PEU, Flash) and to adjust the game's overall pain level. Control LEDs let you monitor the system status in standby and during play.

### Insert Coin Button

Not in use.

### Adjust Painlevel

Rotate Skull to increase/decrease whip speed plus heat & shock durations. Changes take effect during gameplay only!

### Reset Button

Reset electronics / stop pain execution. Software needs to be restarted after use.

### PainControlButtons (PCB)

Use PCBs to test the functionality of the individual pain executing devices. **Warning:** Take out whips before testing! The motor will run at full speed and be very dangerous!

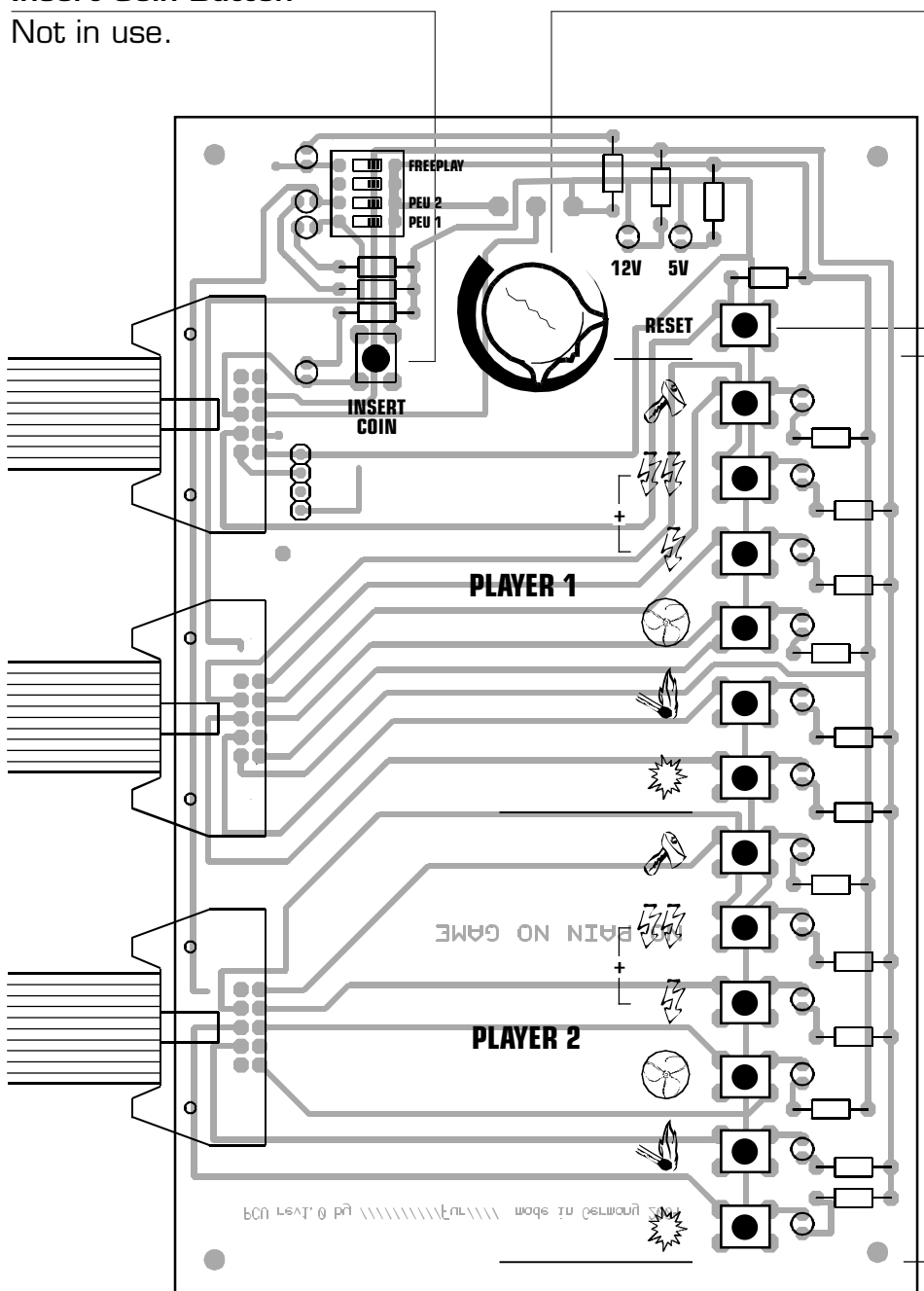

# Brain

## Clean surfaces regularly

Clean the glass surface regularly to get rid of ugly fingerprints and to give the machine the shine it deserves. Use a soft cloth and water with little detergent to clean the other surfaces of the machine.

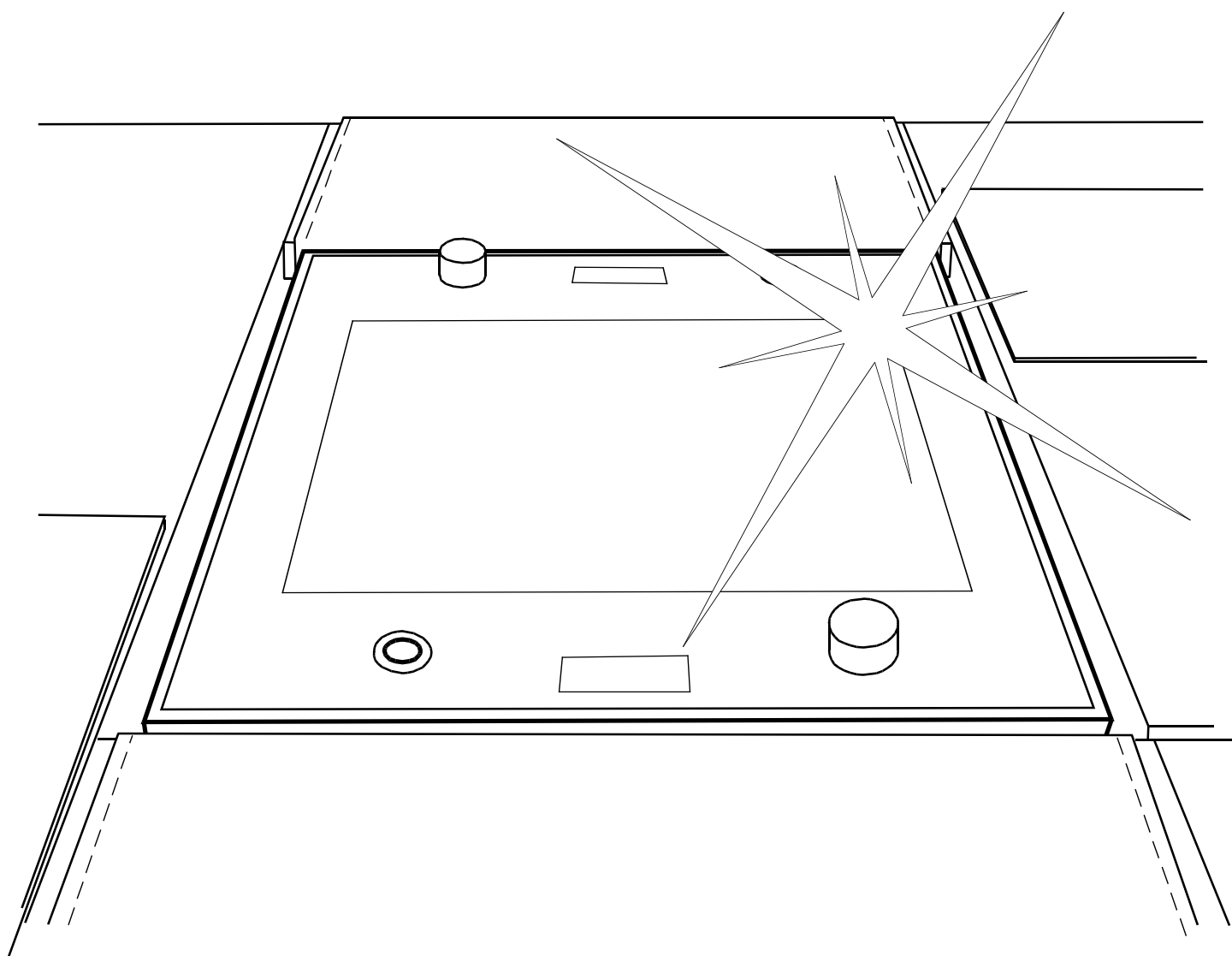

# Credits

## Idea & Realisation

Volker Morawe & Tilman Reiff

## Software

Thomas Wilms & Holger Schebek

## Design Housing

Lars Wichmann & Markus Wessels

## Housing

Jörg & Fritz

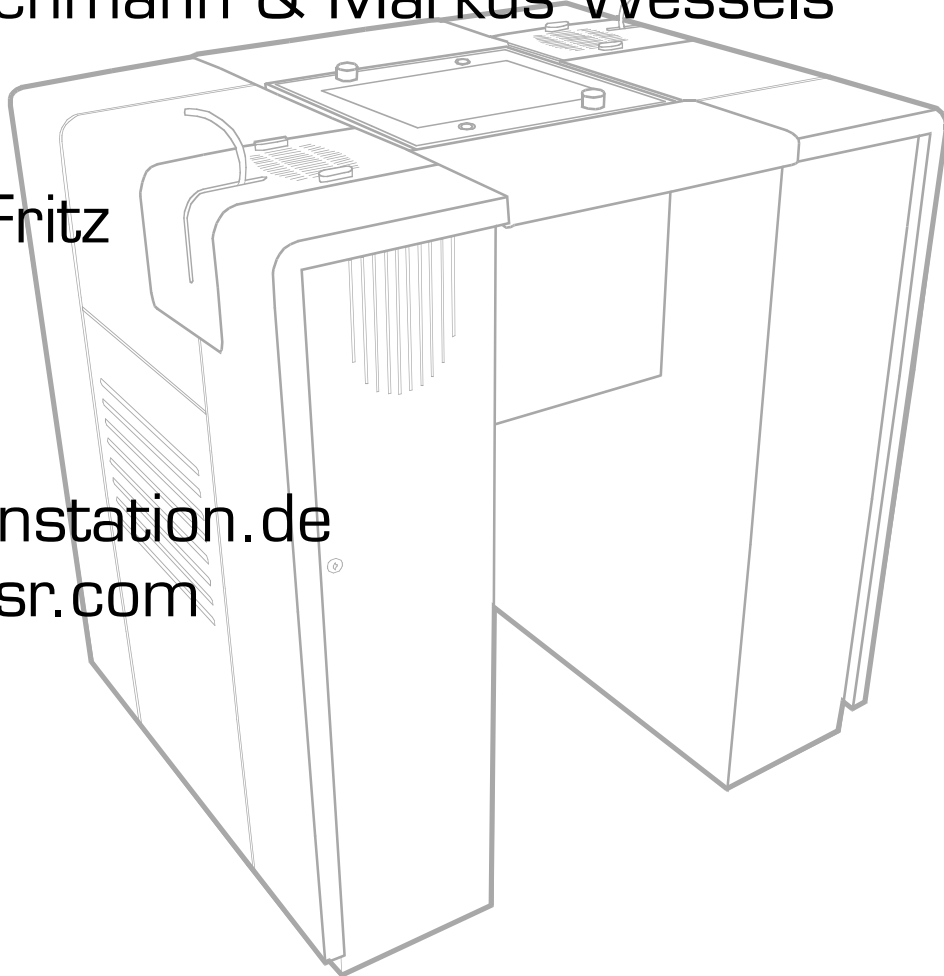

[www.painstation.de](http://www.painstation.de)

[www.fursr.com](http://www.fursr.com)